

# Car Target Up-Down Scoop (VUK) Individual Parts Only (Items 1-24) Continued

## Parts Table & Different Views continued from the previous page.

**DISASSEMBLY FOR REPAIR PROCEDURE FOLLOWS THIS PAGE (98-99A-B) ▼**

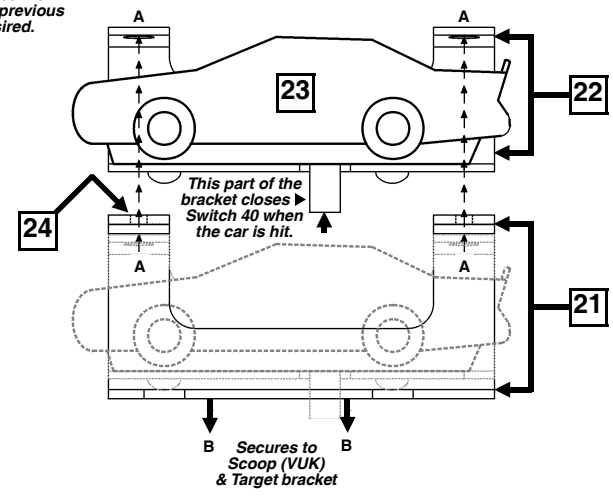
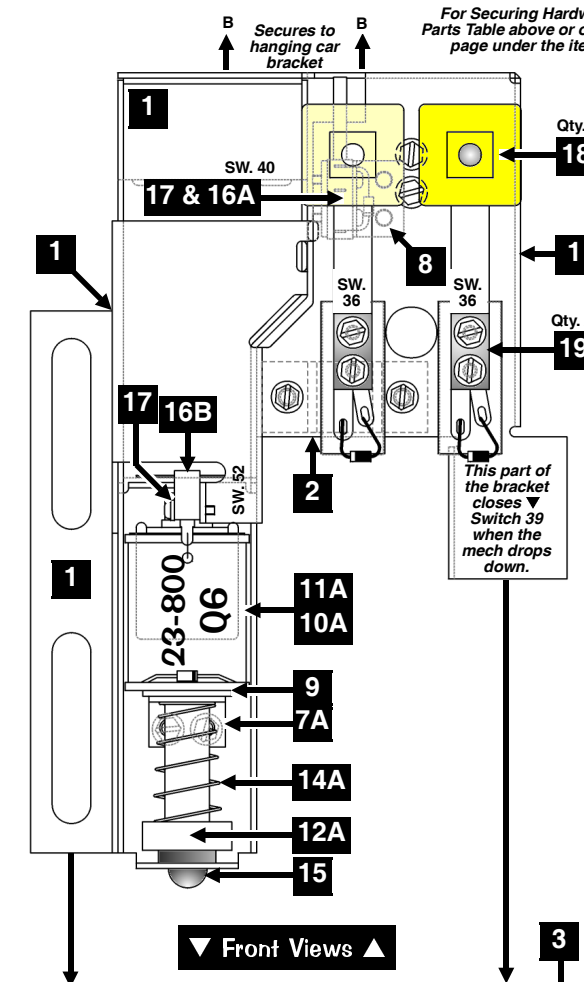

**Nr. CAR TARGET & VUK PARTS QTY. SPI PART Nr.**  
Parts Table & Different Views continued from the previous page.

|   |   |       |                |
|---|---|-------|----------------|
| 17  | Switch Body Protect Plate               | 3     | 535-6539-00    |
| Item 17 is secured to Items 16A & 16B by: #2-56 X 7/16" PPH MS (Zc.) (Qty. 2/per) (237-5872-01)   |   |       |                |
| 18  | Sw. & Target Asm. 1" Sq. (Yellow)       | 2     | 515-5162-06    |
| Item 18 requires : Insulator (Fiche Paper) (Qty. 1/per) (545-6239-00)   |   |       |                |
| For Individual Items use : See Appendix I, Stand-Up Targets, Item 3A (A1-A4)  |   |       |                |
| Switches (Items 16A-C, listed on the previous page, & 18) have a Diode (1N4004) (112-5003-00). Can be replaced with (1N4001) (112-5001-00).   |   |       |                |
| 19  | Sw. Body Protect Plate (Lg. for Stack)  | 2     | 535-5045-00    |
| Item 19 is secured to Item 18 by: #6-32 X 5/8" SHWH (Zc.) (Qty. 2/per) (237-5976-04)  |   |       |                |
| 20  | Foam Pad (Self-Adhesive) (for Item 18)  | 1/per | 626-5029-00    |
| 21  | Bracket, Car Hanger                     | 1     | 535-9633-00    |
| Item 21 is secured above onto Item 1 (Ref. B) by: #8-32 X 3/8" PFH 82° Undercut MS (Zinc) (Qty. 2) (237-6030-00)  |   |       |                |
| 22  | Bracket, Car Mounting                   | 1     | 535-9634-00    |
| Item 24 is secured to Item 21 (Ref. A) by: #8-32 X 3/8" SHWH (Zinc) (Qty. 2) (237-5975-00) and Nut (Pivot) (Qty. 2) (530-5698-00)   |   |       |                |
| 23  | Car (Target) Molded Plastic             | 1     | 545-6233-00-91 |
| Items 23 is secured by: #8-32 X 3/8" PPH MS Ext. Sems (Zinc) (Qty. 4) (232-5301-00)   |   |       |                |
| 24  | Kit: Decals (incl. -CL, -CR, -41 & -42) | 1     | 802-5000-91    |
| Note: Individual Decals (820-6375-XX & 820-6374-XX) are not available individually, ordering of kit is required. For all pieces, see Playfield Top - ... Decals & Mylar Kits, Pg. 69. |   |       |                |

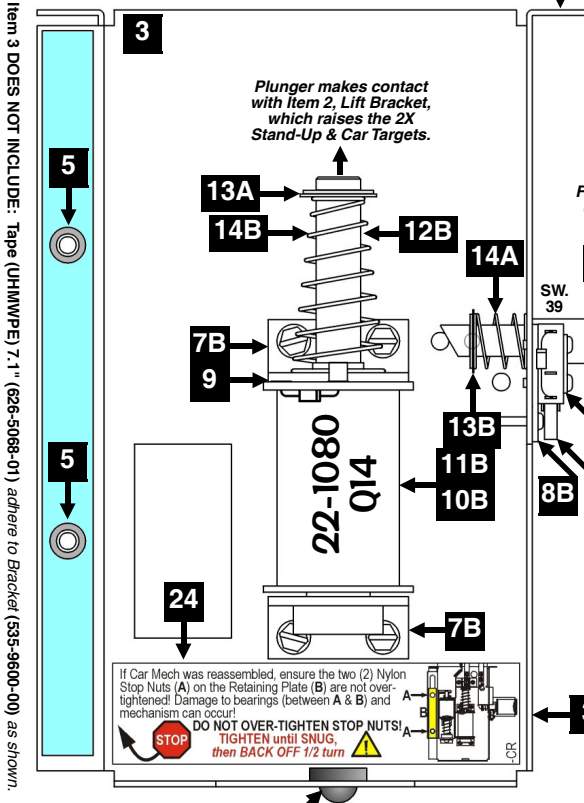

For Securing Hardware, see the Parts Table above or on the previous page under the item desired.

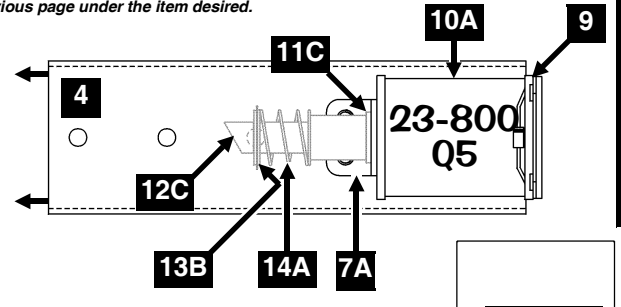

(ASM. REF. 500-6836-00, Items 1-20 without Item 24)  
 (ASM. REF. 515-7424-00, Items 4, 7A (Qty. 1), 9 (Qty. 1), 10A (Qty. 1) & 11C (515-7424-00 doesn't include Items 12C, 13B, 14A))  
 (ASM. REF. 515-7425-00, Items 7B (Qty. 2), 9 (Qty. 1), 10B, 11B, 12B, 13A & 14B)  
 (ASM. REF. 515-7426-00, Items 3, 7B (Qty. 2), 8B, 9 (Qty. 1), 10B, 11B, 12B, +12C, 13A, +13B, +14A (Qty. 1), -14B, +15 (Qty. 1), +16C & +17 (Qty. 1))  
 (ASM. REF. 515-7427-00, Items 1, 2, 7A (Qty. 1), 8A, 9 (Qty. 1), 10A (Qty. 1), 11A, 12A, 14A (Qty. 1), 15 (Qty. 1), 16A, 16B, 17 (Qty. 2), 18 (Qty. 2), 19 (Qty. 2) & 20 (Qty. 2))  
 (ASM. REF. 515-7442-00, Items 22 & 23 without Item 24 (-41, -42))



Sec. 4: Drawings ...