

I/O POWER DRIVER PCB S.A.M. System (520-5249-00) Schematic (Sheet 1 of 4)

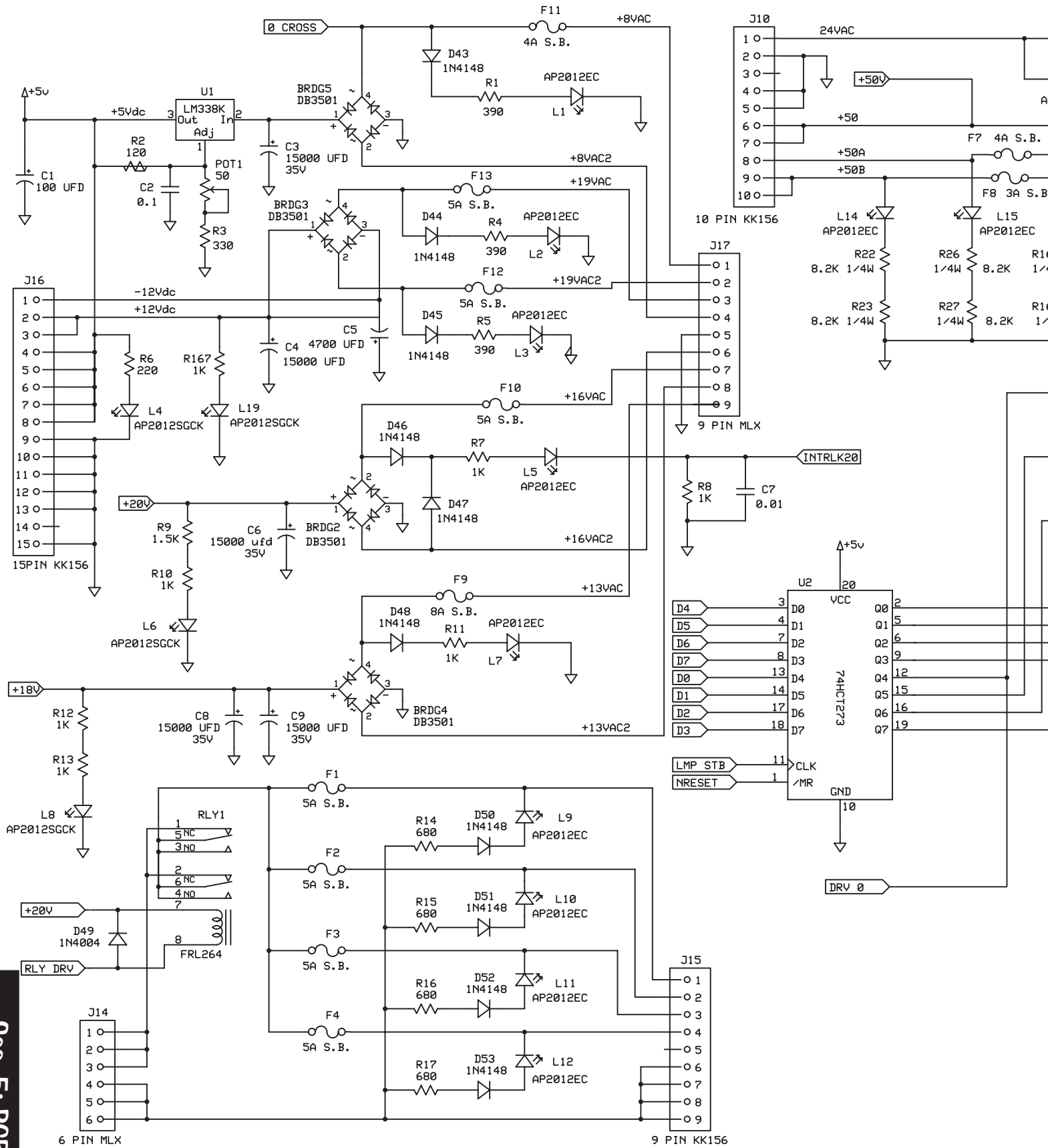

Sec. 5: PCBs

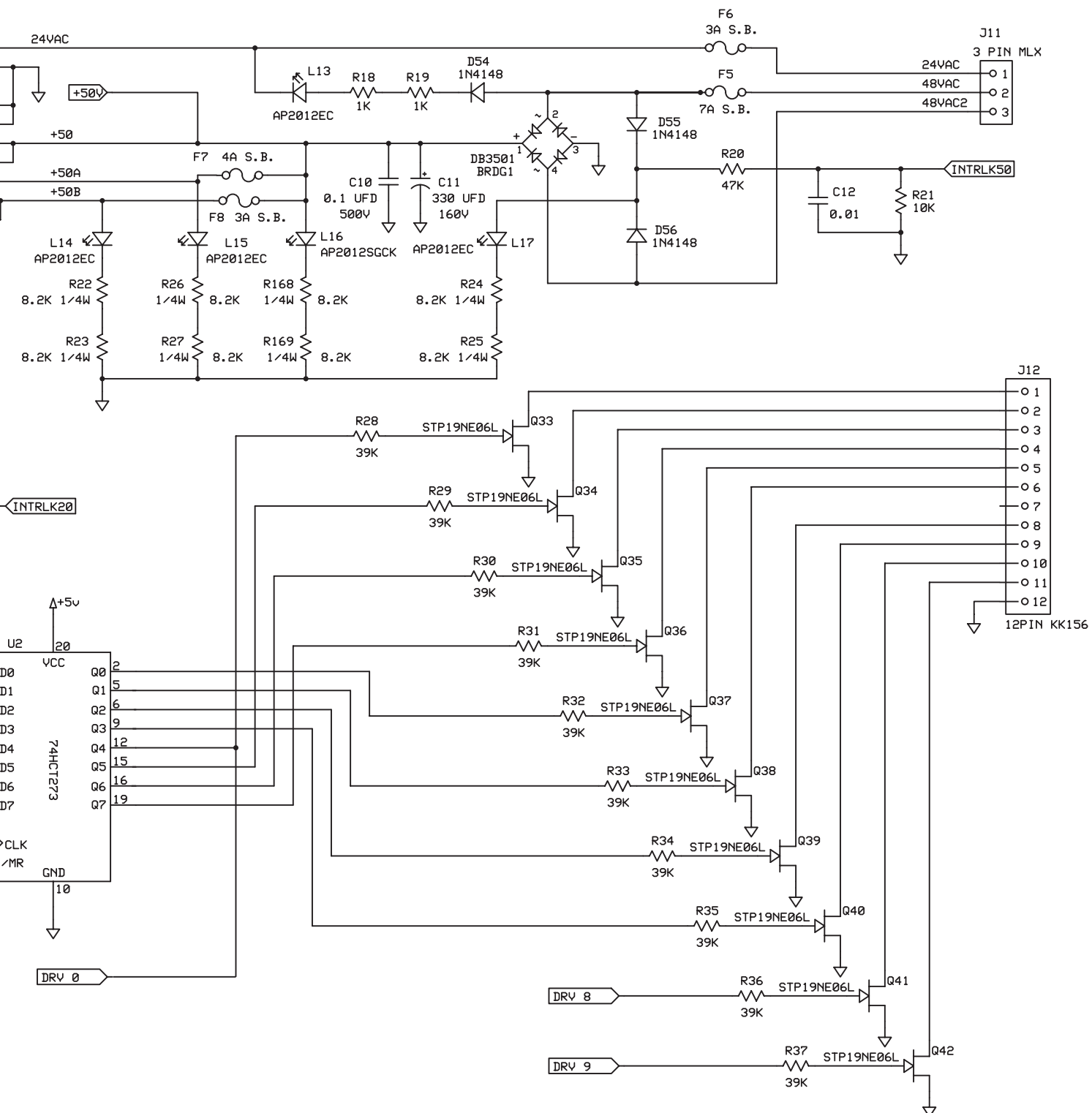



STERN PINBALL, INC.		
I/O POWER DRIVER BOARD		
520-5249-00	Rev A 5/20/2005	Page 1 of 4

Sec. 5: PCBs



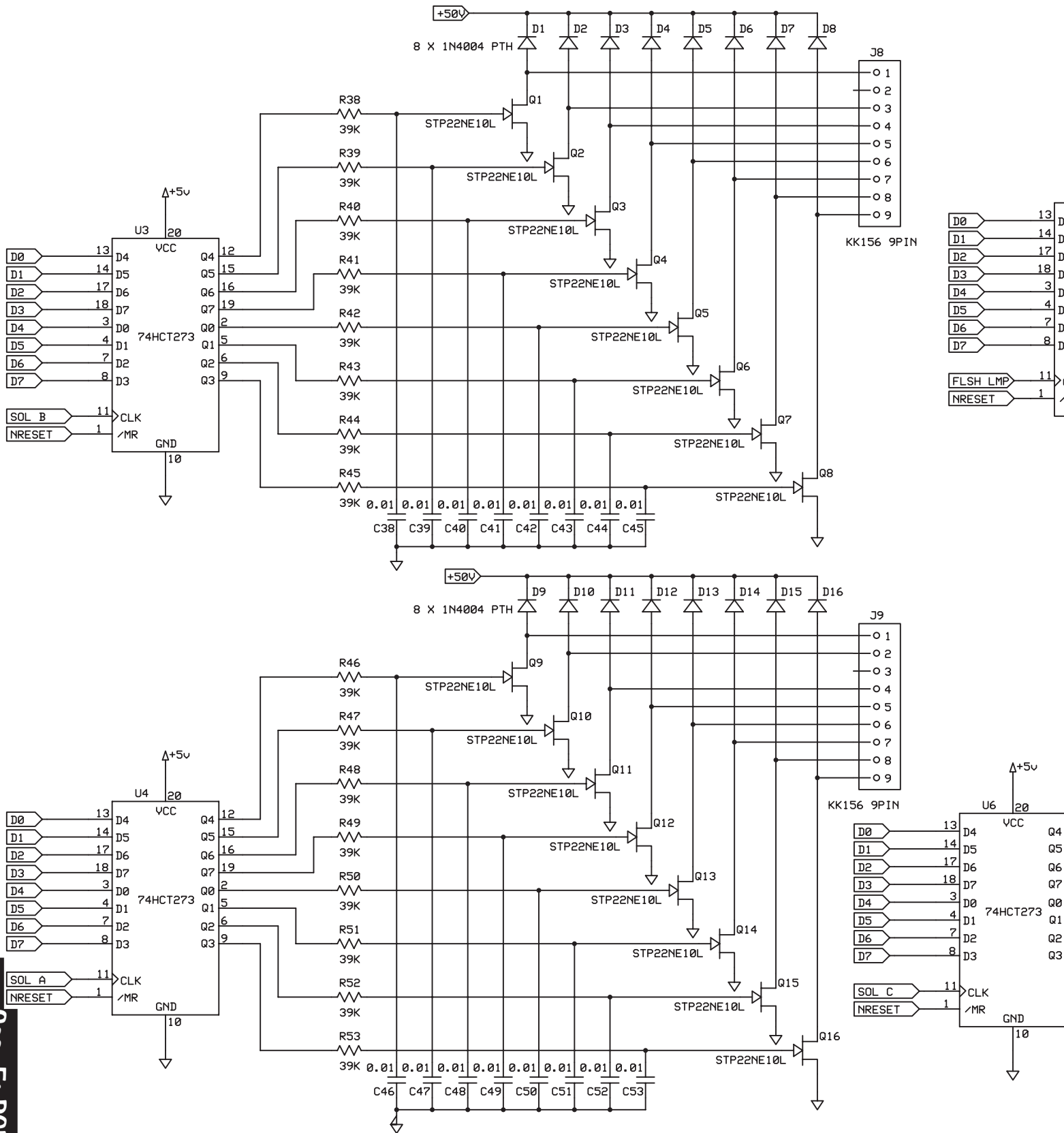

Sec. 5: PCBs



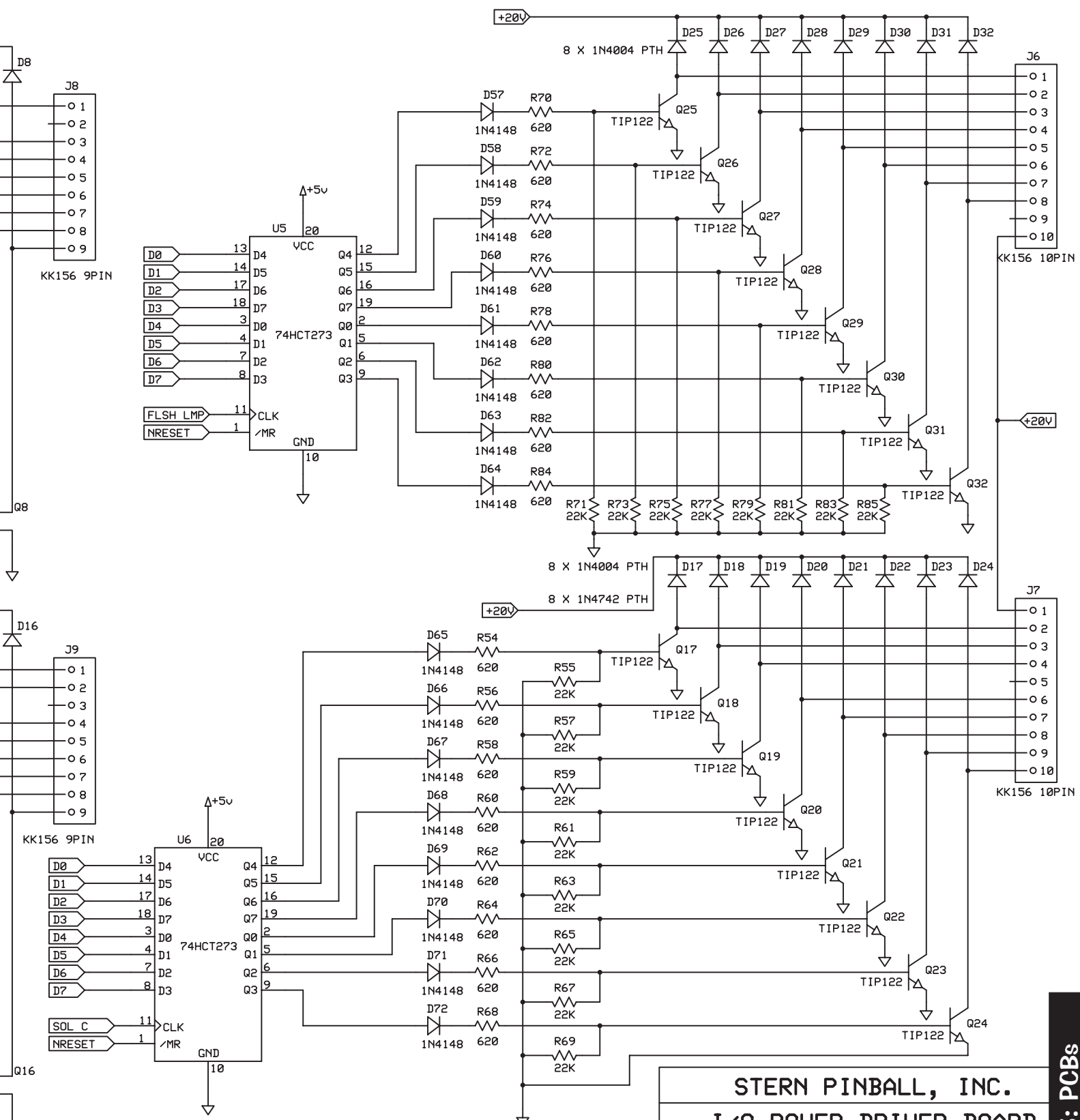

STERN PINBALL, INC.

I/O POWER DRIVER BOARD

520-5249-00	Rev A 5/20/2005	Page 2 of 4
-------------	--------------------	-------------

Sec. 5: PCBs



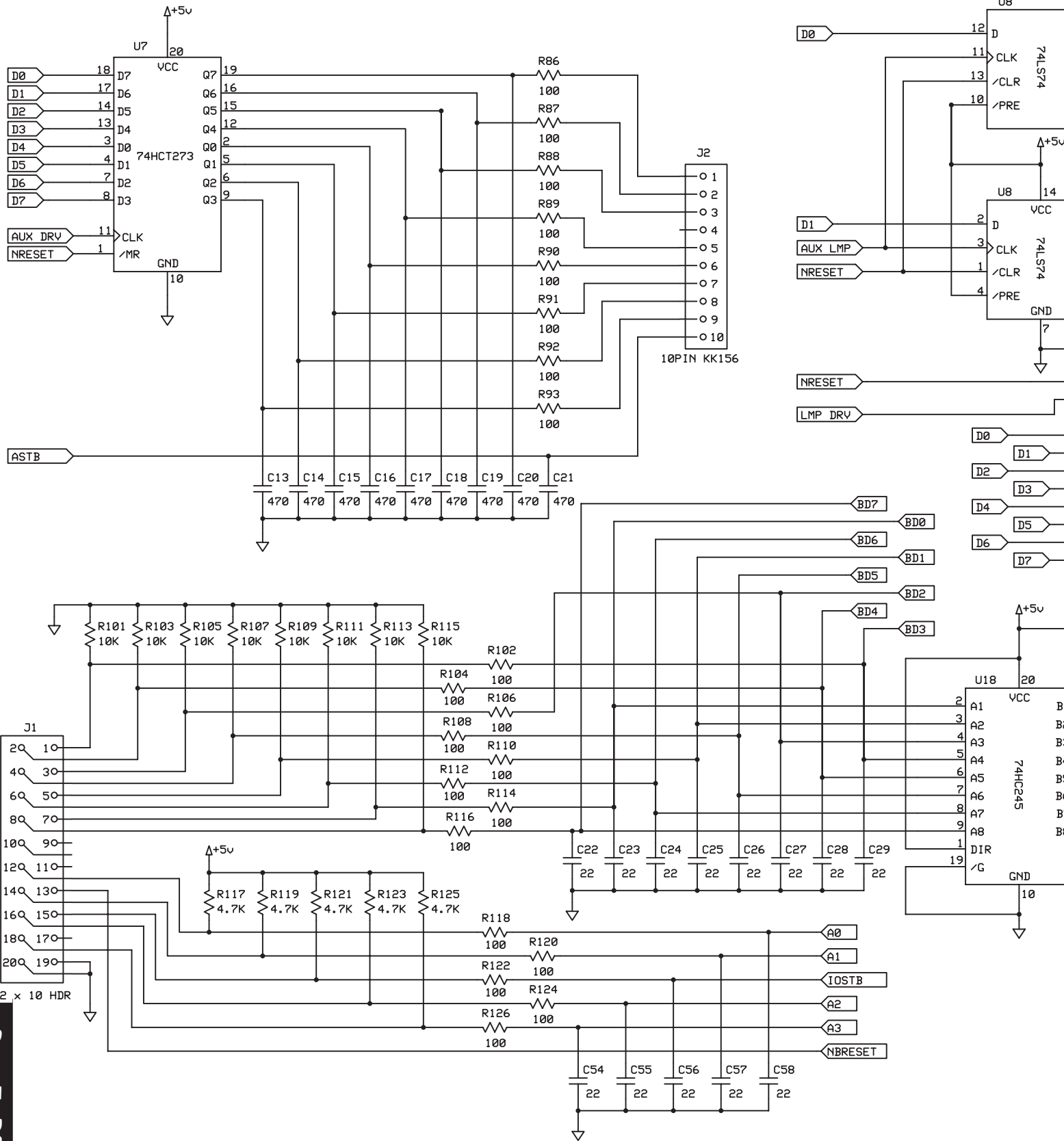

Sec. 5: PCBs



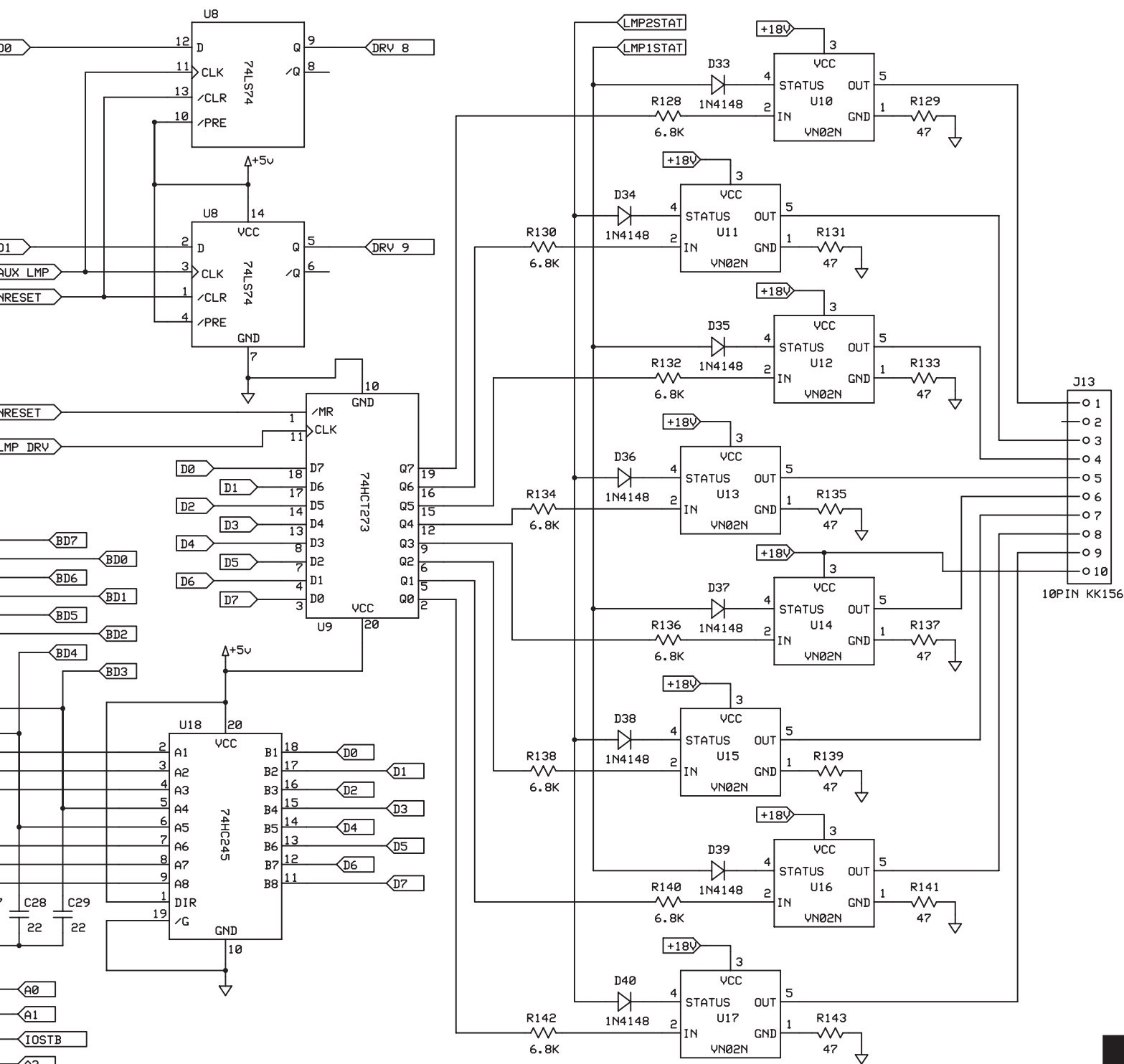

STERN PINBALL, INC.		
I/O POWER DRIVER BOARD		
520-5249-00	Rev A 5/20/2005	Page 3 of 4

Sec. 5: PCBs



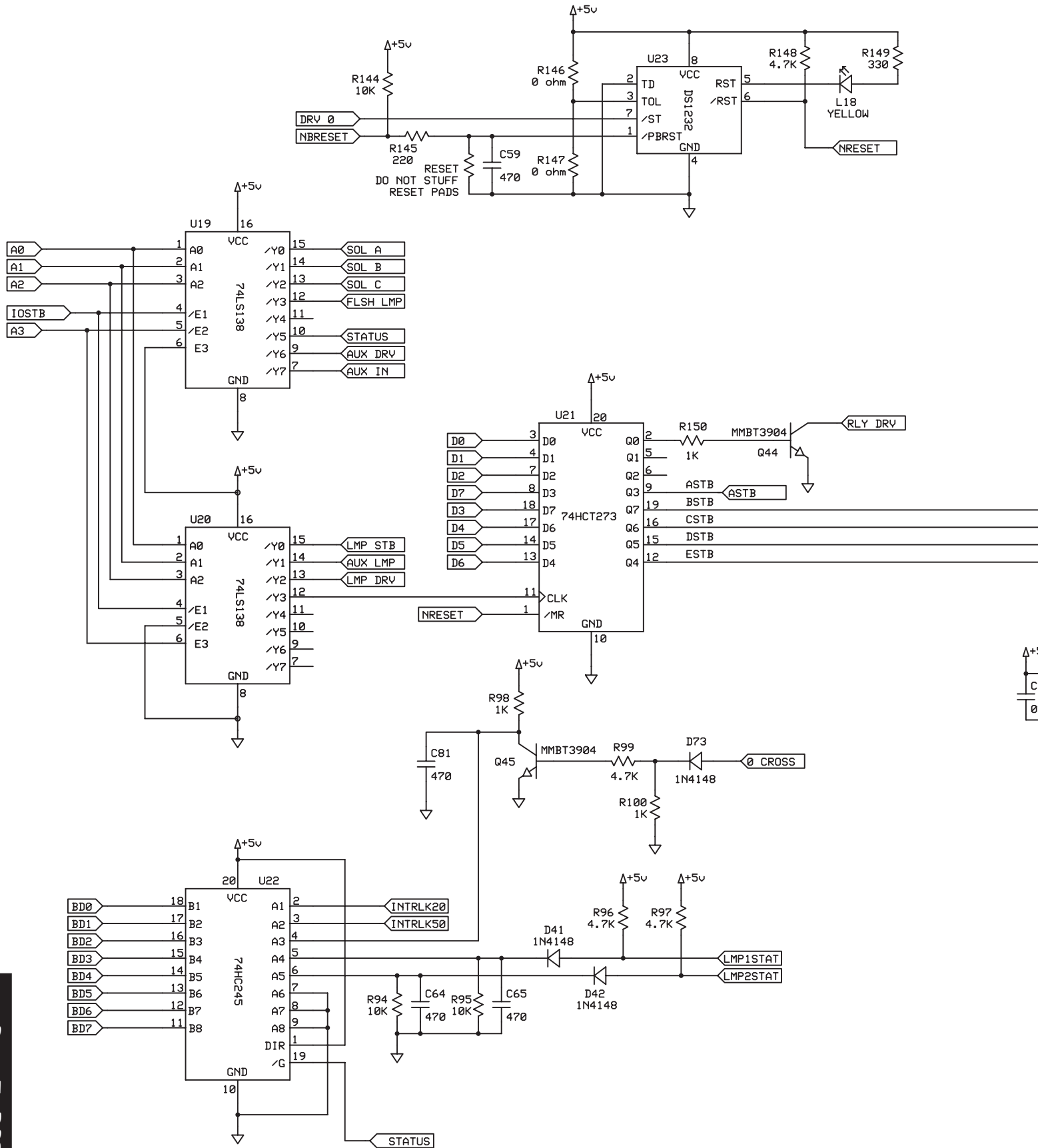

Sec. 5: PCBs



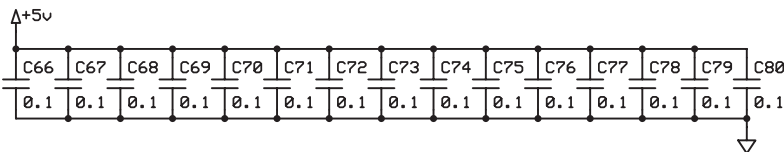
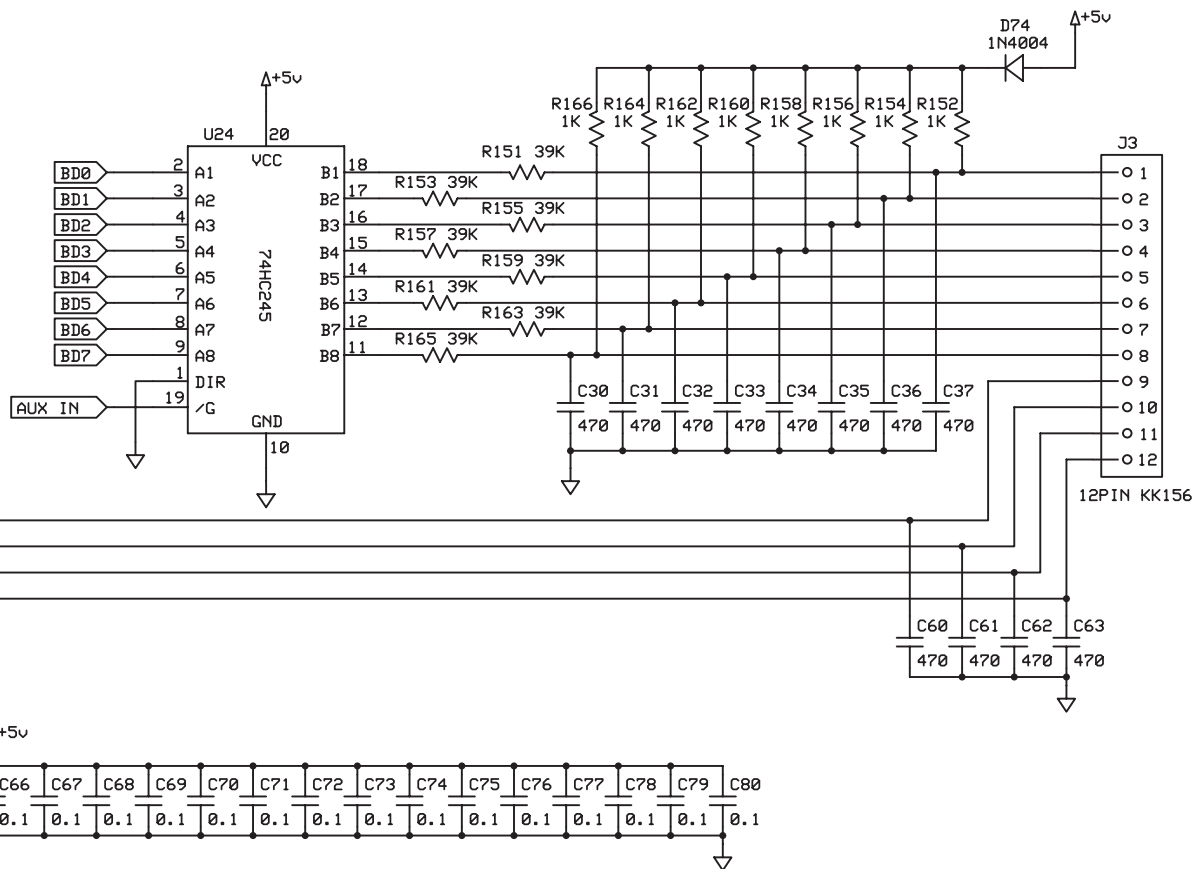
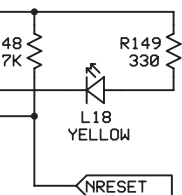

STERN PINBALL, INC.		
I/O POWER DRIVER BOARD		
520-5249-00	Rev A 5/20/2005	Page 4 of 4

Sec. 5: PCBs



I/O POWER DRIVER PCB S.A.M. System (520-5249-00) Component Layout

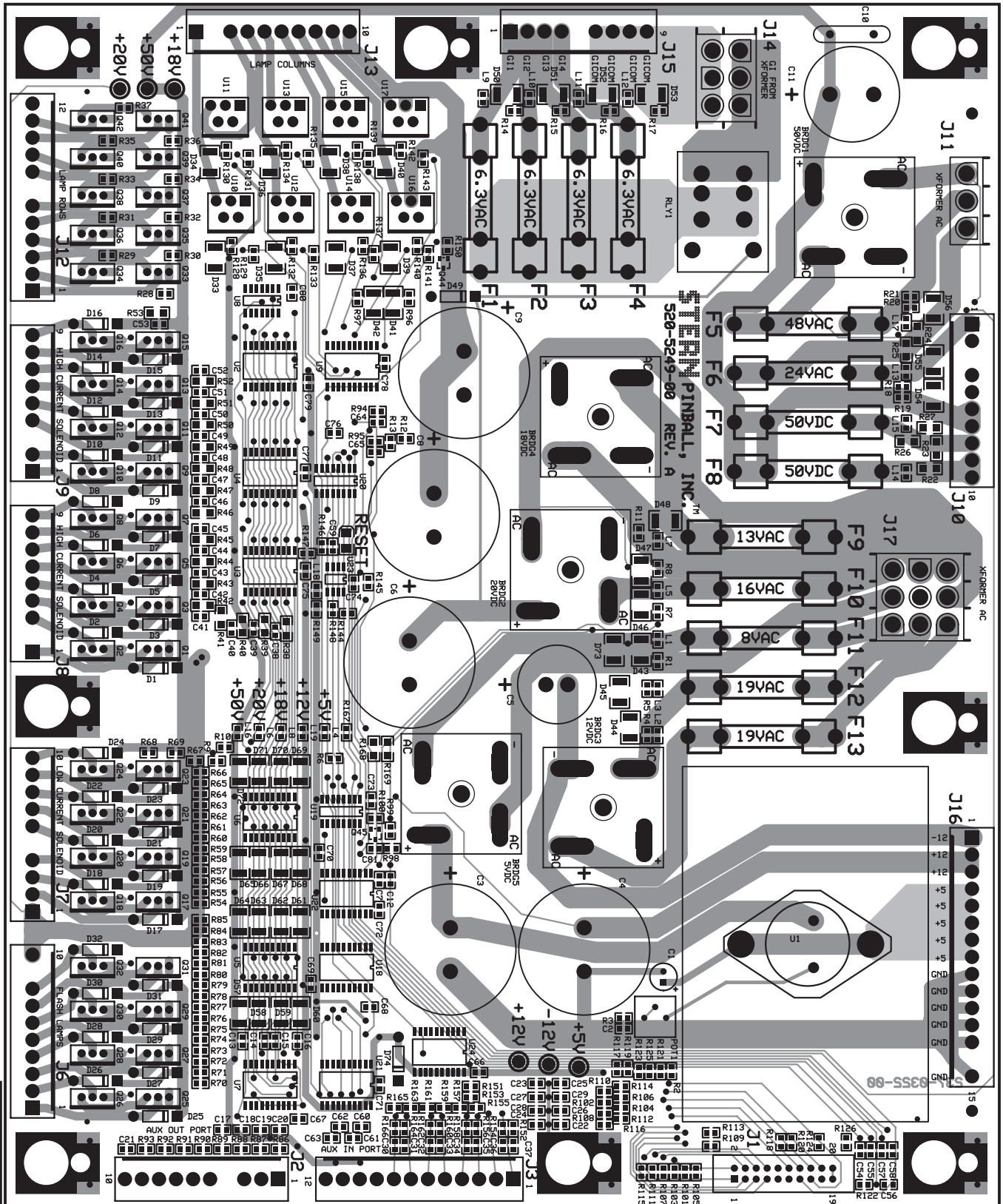

Sec. 5: PCBs



I/O POWER DRIVER PCB S.A.M. System (520-5249-00) Parts

ITEM	QTY.	SPI PART NUMBER	(MFG. P.N.)	REF-DESIGNATOR	DESCRIPTION (SM = Surface Mount)
—	1	520-5249-00		I/O Power Driver PCB (S.A.M. System), Rev. A	<i>(includes Items 1-67)</i>
1	1	121-6001-00	(101-0001807)	R9	Resistor SM 0805 Film 1.5KΩ 1/10W 5%
2	22	121-6002-00	(101-0001820)	R86, R87, R88, R89, R90, R91, R92, R93, R102, R104, R106, R108, R110, R112, R114, R116, R118, R120, R122, R124, R126, R146, R21, R94, R95, R101, R103, R105, R107, R109, R111, R113, R115, R144	Resistor SM 0805 Film 100Ω 1/10W 5%
3	12	121-6020-00	(101-0001827)	R2	Resistor SM 0805 Film 10KΩ 1/10W 5%
4	1	121-6003-00	(101-0001845)	R7, R8, R10, R11, R12, R13, R18, R19, R98, R100, R150, R152, R154, R156, R158, R160, R162, R164, R166, R167	Resistor SM 0805 Film 120Ω 1/10W 5%
5	20	121-6022-00	(101-0001905)	R6, R145	Resistor SM 0805 Film 1KΩ 1/10W 5%
6	2	121-6004-00	(101-0001943)	R55, R57, R59, R61, R63, R65, R67, R69, R71, R73, R75, R77, R79, R81, R83, R85	Resistor SM 0805 Film 220Ω 1/10W 5%
7	16	121-6005-00	(101-0001849)	R3, R149	Resistor SM 0805 Film 22KΩ 1/10W 5%
8	2	121-6006-00	(101-0002012)	R1, R4, R5	Resistor SM 0805 Film 330Ω 1/10W 5%
9	3	121-6007-00	(101-0002031)	R151, R153, R155, R157, R159, R161, R163, R165	Resistor SM 0805 Film 390Ω 1/10W 5%
10	8	121-6013-00	(101-0002035)	R96, R97, R99, R117, R119, R121, R123, R125, R148	Resistor SM 0805 Film 39KΩ 1/10W 5%
11	9	121-6008-00	(101-0002046)	R129, R131, R133, R135, R137, R139, R141, R143	Resistor SM 0805 Film 4.7KΩ 1/10W 5%
12	8	121-6014-00	(101-0002065)	R20	Resistor SM 0805 Film 47Ω 1/10W 5%
13	1	121-6015-00	(101-0002071)	R128, R130, R132, R134, R136, R138, R140, R142	Resistor SM 0805 Film 47KΩ 1/10W 5%
14	8	121-6009-00	(101-0002108)	R54, R56, R58, R60, R62, R64, R66, R68, R70, R72, R74, R76, R78, R80, R82, R84	Resistor SM 0805 Film 6.8KΩ 1/10W 5%
15	16	121-6010-00	(101-0002116)	R14, R15, R16, R17	Resistor SM 0805 Film 620Ω 1/10W 5%
16	4	121-6016-00	(101-0002126)	R28, R29, R30, R31, R32, R33, R34, R35, R36, R37	Resistor SM 0805 Film 680Ω 1/10W 5%
17	10	121-6011-00	(101-0002296)	R22, R23, R24, R25, R26, R27, R168, R169	Resistor SM 1206 Film 22KΩ 1/10W 5%
18	8	121-6012-00	(101-0002473)	R38, R39, R40, R41, R42, R43, R44, R45, R46, R47, R48, R49, R50, R51, R52, R53	Resistor SM 1206 Film 8.2KΩ 1/10W 5%
19	16	121-6013-01	(101-0002378)	C2, C66, C67, C68, C69, C70, C71, C72, C73, C74, C75, C76, C77, C78, C79, C80	Resistor SM 1206 Film 39KΩ 1/10W 5%
20	16	125-6001-00	(121-0000056)	C13, C14, C15, C16, C17, C18, C19, C20, C21, C30, C31, C32, C33, C34, C35, C36, C37, C59, C60, C61, C62, C63, C64, C65, C81	Capacitor SM 0805 Cer. .1uF 50V 10% X7R
21	25	125-6002-00	(121-0000096)	C7, C12, C38, C39, C40, C41, C42, C43, C44, C45, C46, C47, C48, C49, C50, C51, C52, C53, C22, C23, C24, C25, C26, C27, C28, C29, C54, C55, C56, C57, C58	Capacitor SM 0805 Cer. 470PF 50V 5% NPO
22	18	125-6003-00	(121-0004236)	C1	Capacitor SM 0805 Cer. .01uF 50V 10% X7R
23	13	125-6004-00	(121-0005318)	C5	Capacitor SM 0805 Cer. 22PF 100V 5% NPO
24	1	125-5032-00	(131-0003773)	C10	Capacitor Tht. Radial Alum. 100uF 25V 20%
25	1	125-5034-00	(131-0003864)	C11	Capacitor Tht. Radial Alum. 4700uF 35V 20%
26	1	125-5029-01	(133-0003741)	C3, C4, C6, C8, C9	Capacitor Tht. Disc Cer. .1uF 500V 20%
27	1	125-6022-00	(134-0003846)	D1, D2, D3, D4, D5, D6, D7, D8, D9, D10, D11, D12, D13, D14, D15, D16, D17, D18, D19, D20, D21, D22, D23, D24, D25, D26, D27, D28, D29, D30, D31, D32, D49, D74	Capacitor Tht. Radial Alum. 330uF 160V 20%
28	5	125-5036-01	(134-0004000)	BRDG1, BRDG2, BRDG3, BRDG4, BRDG5	Cap. Tht. Rad. Al. 15000uF 35V 20% Snap-In
29	34	112-6001-01	(183-0004374)	Q33, Q34, Q35, Q36, Q37, Q38, Q39, Q40, Q41, Q42	Diode Tht. DO-41 1N4004 400V 1A
30	5	112-5000-00	(187-0004700)	Q1, Q2, Q3, Q4, Q5, Q6, Q7, Q8, Q9, Q10, Q11, Q12, Q13, Q14, Q15, Q16	Bridge Tht. Fullwave 100V 35A MB-35
31	10	110-0088-01	(203-0003591)	U10, U11, U12, U13, U14, U15, U16, U17	Fet Tht. TO-220 STP20NE06L NFet 60V 20A
32	16	110-0106-00	(203-0003592)	Q44, Q45	Fet Tht. TO-220 20N10L NFet 100V 20A
33	8	110-0089-00	(203-0003597)	Q17, Q18, Q19, Q20, Q21, Q22, Q23, Q24, Q25, Q26, Q27, Q28, Q29, Q30, Q31, Q32	Fet Tht. PENTAWAT VN02N NFet HighSide 26V 6A
34	2	110-0069-01	(211-0003589)	U18, U22, U24	Trans. SM SOT-23 MMST3904 NPN 40V 0.2A
35	16	110-0067-00	(213-0003565)	U1	Transistor Tht. TO-220 TIP122 NPN 100V 5A
36	3	100-6003-00	(221-0000972)	U2, U3, U4, U5, U6, U7, U9, U21	I.C. SM SOIC 74HC245 Oct. Bus. Xcvr.
37	1	100-6000-00	(221-0011253)	U19, U20	I.C. SM SOIC DS1832S, SO-8
38	8	100-5056-00	(221-0001287)	U8	I.C. SM SOIC 74HCT273 Oct. D F-F
39	2	100-6001-00	(221-0003728)	U1	I.C. SM SO 74LS138D Hex Inverter; 3-8 DC/DMX
40	1	100-6002-00	(221-0011135)	U1	I.C. SM SOIC 74LS74AD SOIC-14
41	1	100-0356-00	(225-0003582)	J2, J6, J7, J10, J13	I.C. Tht. TO-3 LM338 5A Adjust. Voltage Reg.
42	5	045-	(315-0003427)	J1	Con. Tht. Hdr. 10 Pin, 1 Row .156"
43	1	045-	(315-0006910)	J3, J12	Con. Tht. Hdr. 20 Pin, 2 Row .1"
44	2	045-	(315-0003430)	J16	Con. Tht. Hdr. 12 Pin, 1 Row .156"
45	1	045-	(315-0003432)	J11	Con. Tht. Hdr. 15 Pin, 1 Row .156"
46	1	045-	(315-0003503)	J14	Con. Tht. Pwr. 3 Pin, 1 Row .25"
47	1	045-	(315-0003504)	J17	Con. Tht. Pwr. 6 Pin, 2 Row .25"
48	1	045-	(315-0003505)	J8, J9, J15	Con. Tht. Pwr. 9 Pin, 3 Row .25"
49	3	045-	(315-0003821)	F6, F8	Con. Tht. Hdr. 9 Pin, 1 Row .156"
50	2	200-5000-08	(407-0003117)	F7, F11	Fuse 3 Amp 250V Slo-Blo (Glass, Tht. 3AG)
51	2	200-5000-06	(407-0003118)	F1, F2, F3, F4, F10, F12, F13	Fuse 4 Amp 250V Slo-Blo (Glass, Tht. 3AG)
52	7	200-5000-01	(407-0003119)	F5	Fuse 5 Amp 250V Slo-Blo (Glass, Tht. 3AG)
53	1	200-5000-03	(407-0003121)	F9	Fuse 7 Amp 250V Slo-Blo (Glass, Tht. 3AG)
54	1	200-5000-05	(407-0003122)	POT1	Fuse 8 Amp 250V Slo-Blo (Glass, Tht. 3AG)
55	1	121-5039-00	(415-0004788)	L18	Potentiometer THT 50Ω Single Top Adjust. Trimr.
56	1	165-6000-00	(425-0006913)	L4, L6, L8, L16, L19	LED SM Yellow 0805 LED
57	5	165-6001-00	(425-0007753)	L1, L2, L3, L5, L7, L9, L10, L11, L12, L15, L17	LED SM Green Ultrabright Top
58	13	165-6002-00	(425-0007755)	RLY1	LED SM Red Ultrabright Top 0805 LED
59	1	190-5002-00	(448-0004778)	for BRDG 4, BRDG 5	Relay Tht. GW DPDT10A DC24 2400VA PC MNT
60	1	127-5001-00	(461-0003520)	for U1	Heatsink, Sq. Finned Ba TO-220 Avid 531102
61	1	127-5001-02	(461-0003534)	for U1 on TO-3 LM338 5A Adj. Volt. Reg.	Heatsink All Large Finned Alum. TO-3
62	1	127-5001-04	(579103B00000G)	2 pcs. for U1 1 pc. each for BRDG 4 & 5	Heatsink, Circular Finned (Mfg. Aavid)
63	4	240-5008-00	(503-0004469)	2 pcs. each for F1 - F13	#6-32 Keps Nut
64	26	205-0004-00	(503-0004667)	2 pcs. for U1 1 pc. each for BRDG 4 & 5	Fuseclip with End Stops (+ Ears)
65	4	237-5504-00	(504-0004610)	for BRDG 4 & 5 (Mfg. .169" I.D. X 9/32" O.D. X 1/4")	#6-32 X 3/4" PPH MS (Zinc) Screw
66	2	254-5007-02	(507-0004544)	for BRDG1, 2 & 3 and for Mounting Holes	1/4" Sif. Rtn. Spacer White
67	5	254-5007-05	(507-0004547)		5/16" Sif. Rtn. Spacer White

Sec. 5: PCBs

