

Cabinet and Coin Door Wiring

Transformer Power Wiring Diagram

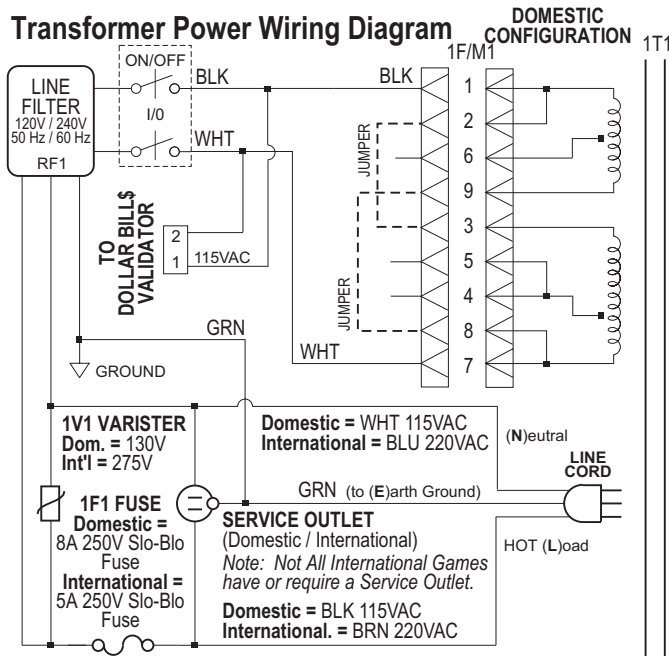

▼ Jumper Configurations for Voltage Variations ▼

N. AMERICA LINE VOLTAGE
110VAC / 120VAC

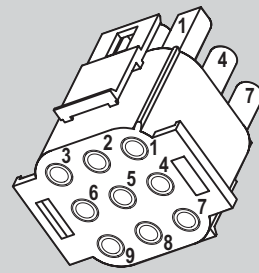
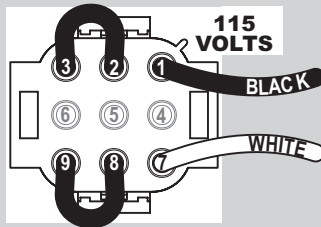

INTERNATIONAL or HIGH LINE VOLTAGE
230VAC / 218VAC / 206VAC

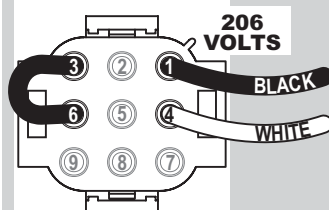
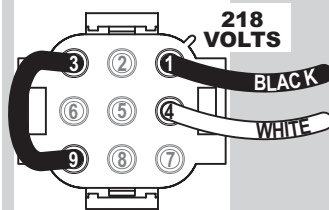
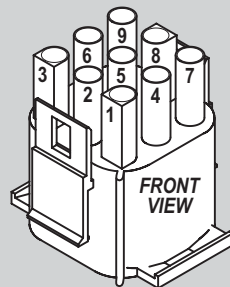
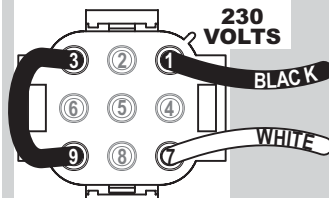

JAPAN or LOW LINE VOLTAGE
100VAC / 105VAC

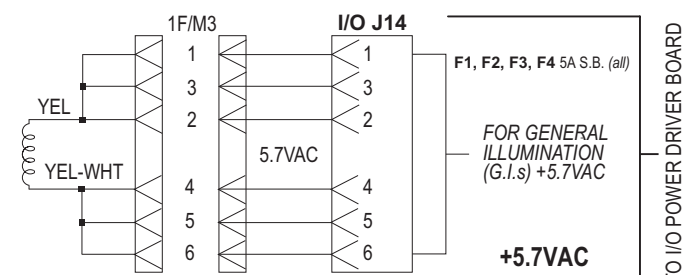
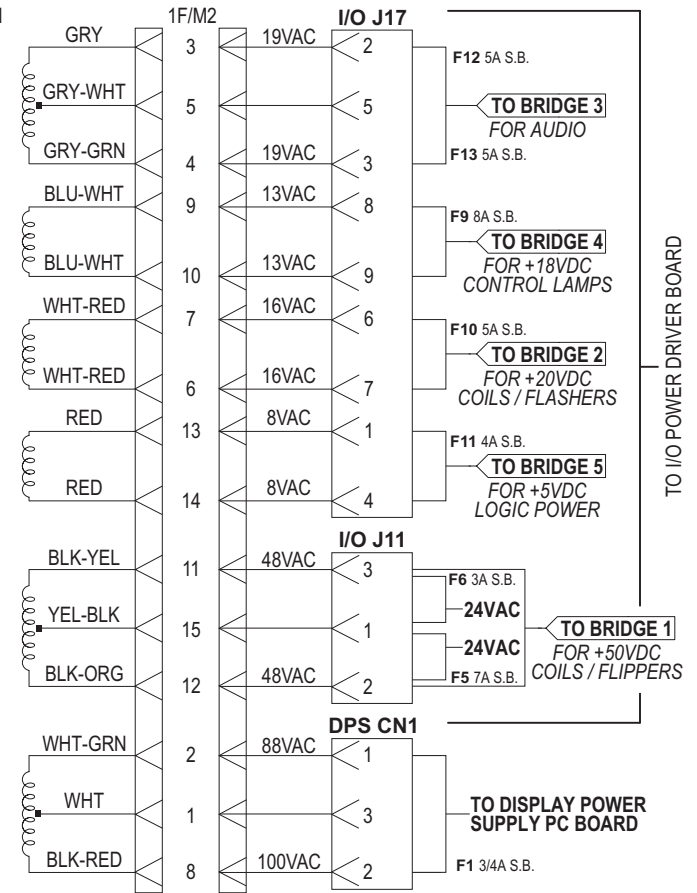
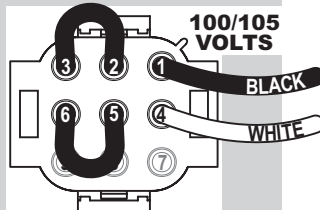

ALL FUSES RATED 250V SLO-BLO DO NOT OVERFUSE ▲

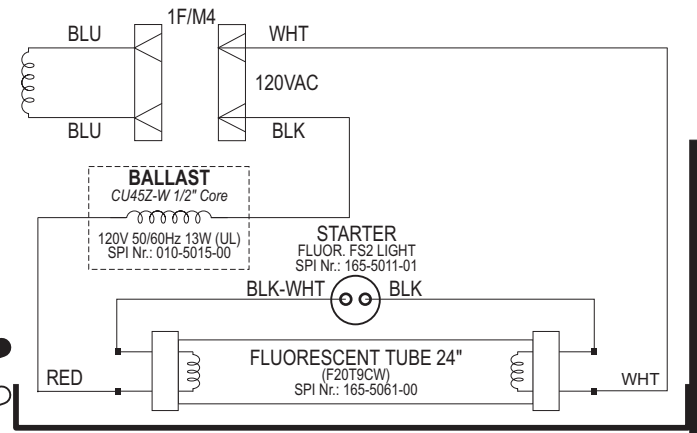

Sec. 5: Cab. & Coin

Cabinet Wiring Diagram

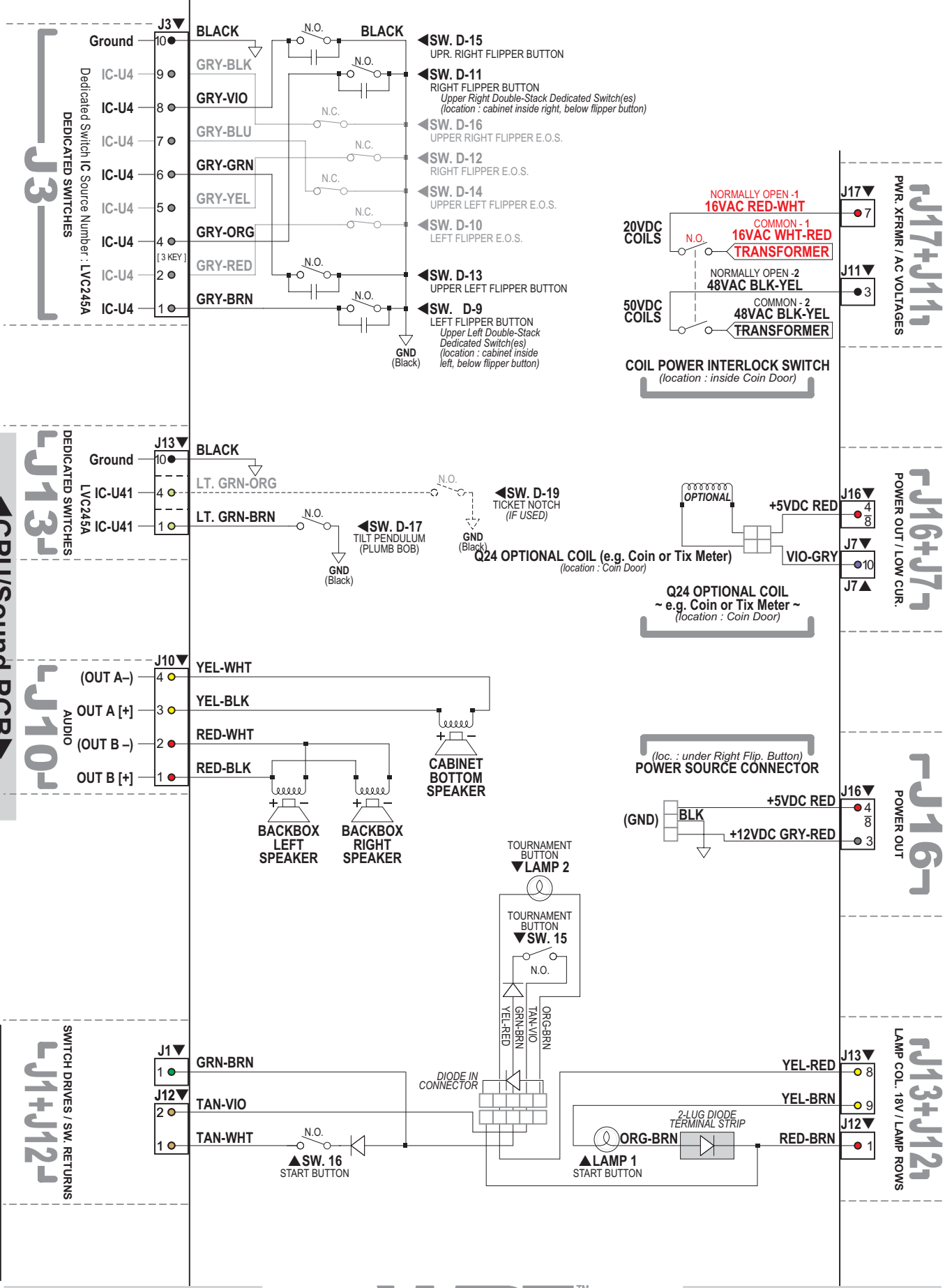

I/O POWER DRIVER PCB

CPU/Sound PCB

Sec. 5: Cab. & Coin

▲ CPU/Sound PCB ▲

▲ I/O POWER DRIVER PCB ▲

Coin Door Wiring Diagram

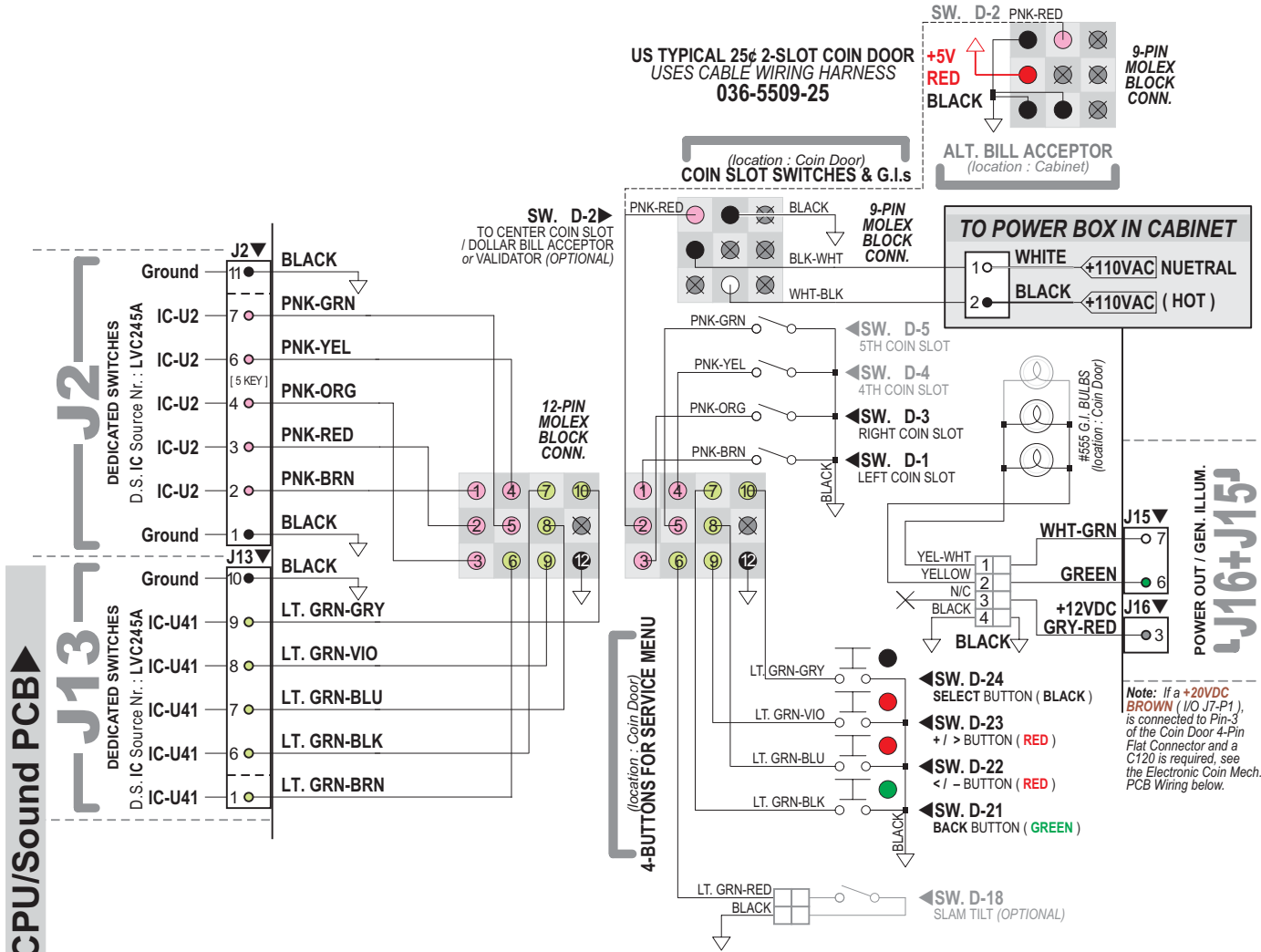

1-SLOT COIN DOOR WITH C120 CAPABILITIES (NO INTERFACE COIN MECH PCB REQUIRED)
USES CABLE WIRING HARNESS
036-5509-31A (+12VDC GRY-RED)

036-5509-31B (ICT/KAL ONLY) / 036-5509-31C (ODA ONLY) / 036-5509-31D (SPAIN ONLY)

NON-US NON-C120 2-SLOT COIN DOOR
USES CABLE WIRING HARNESS
036-5509-32

NON-US NON-C120 3-SLOT COIN DOOR
USES CABLE WIRING HARNESS
036-5509-33

IF YOUR GAME HAS AN ELECTRONIC COIN MECH. INTERFACE PC BOARD (520-5193-00):

1-SLOT COIN DOOR USE WITH C120 CAPABILITIES REQUIRING PCB 520-5193-00
USES CABLE WIRING HARNESS
036-5509-31 (S.A.M. SYSTEM)

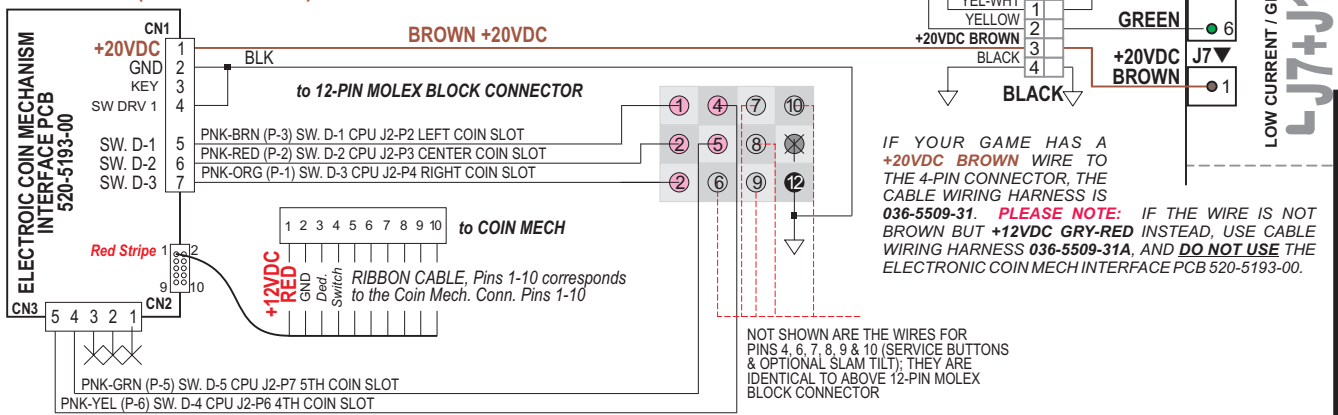

~ WIRING CONFIGURATION WILL VARY ACCORDING TO COUNTRY ~

